

## Bidirectional Homopolar Magnetic Bearings with Fault Tolerant Capability

Uhn Joo Na, Jin Seok Won, Hyun Ok Kang, Dong Dae Lee

Division of Mechanical Engineering and Automation, Kyungnam University, MasanI, Korea  
 (Tel : +82-55-249-2162; E-mail: uhnjoona@kyungnam.ac.kr)

**Abstract:** A fault tolerant current distribution scheme is presented for a bi-directional magnetic bearing with reduced eddy currents and cross coupled stiffness. The bearing continues to function normally even though one coil among four radial coils and one coil of two axial coils fail. The dynamic properties and load capacity remain unchanged for the suggested fault tolerant control scheme at the cost of additional hardware such as a decoupling choke, additional DSP channels, and power amplifiers. A one-dimensional circuit that represents the bi-directional bearing is utilized to obtain the optimal bearing parameters such as the radial pole face area, number of coil turns, and permanent magnet size.

**Keywords:** Magnetic bearings, rotor dynamics.

### 1. INTRODUCTION

Unlike heteropolar bearings, homopolar magnetic bearings have a unique biasing scheme that directs the bias flux flow into the active pole plane where it energizes the working air gaps, and then returns through the dead pole plane and the shaft sleeve. Some of the results on modeling, design, and control of homopolar magnetic bearings are shown in literature. Meeks [1] utilized a permanent magnet biased homopolar magnetic bearing to provide smaller, lighter, and power-efficient operation. Fault-tolerance of the magnetic bearing system is of great concern for highly critical applications of turbomachinery since a failure of any one control components may lead to the complete system failure. Much research has been devoted to fault-tolerant heteropolar magnetic bearings. Maslen and Meeker [2] introduced a fault-tolerant 8-pole magnetic bearing actuator with independently controlled currents and experimentally verified it in [3]. Flux coupling in heteropolar magnetic bearings allows the remaining coils to produce force resultants identical to the unfailed bearing, if the remaining coil currents are properly redistributed. Na and Palazzolo [4, 5] also investigated the optimized realization of fault-tolerant magnetic bearing actuators, so that fault-tolerant control can be realized for an 8-pole bearing for up to 5 coils failed. This paper introduces a fault-tolerant 4-active-pole permanent magnet biased, bi-directional magnetic bearing such that the bearing can preserve the same decoupled magnetic forces identical to the unfailed bearing even after any one coil out of 4 coils fails.

### 2. MAGNETIC CIRCUIT ANALYSIS

Figure 1 shows a schematic drawing of a permanent magnet biased combo bearing. Four independent coils are wound on each radial pole to supply control fluxes. A pair of coils supplies axial control fluxes. The bi-directional bearing shown in Fig. 1 is represented as a 1-D magnetic circuit if eddy current effects and path reluctances are assumed negligible. The equivalent magnetic circuit for the combo bearing is shown in Fig. 2.

The first part includes the paper title, authors' name, abstract, and keywords. All fonts must be in Times New Roman, and the font size of the title, authors' name, affiliation, abstract, and keywords are bold 12pt, 11pt, 10pt, 10pt, and 10pt, respectively.

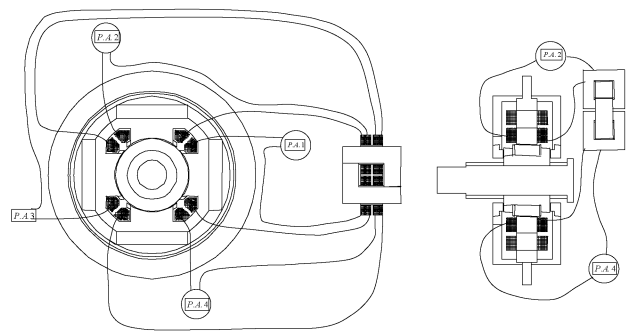

Fig. 1 Schematic of a Bidirectional Magnetic Bearing

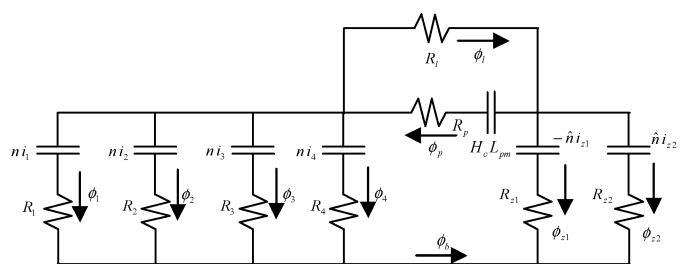

Fig. 2 Equivalent Circuit for a Bidirectional Bearing

The permanent magnets are represented as the source  $H_c L_{pm}$  and the total permanent magnet reluctance  $R_p$ . The coercive force and the length of the permanent magnet are  $H_c$  and  $L_{pm}$ , respectively. The reluctance in air gap  $j$  of the active pole plane is;

$$R_j = \frac{g_j}{\mu_0 a_0} \quad (1)$$

where

$$g_j = g_0 - x \cos \theta_j - y \sin \theta_j \quad (2)$$

The parameters  $\mu_0$ ,  $a_0$ , and  $g_0$  represent the permeability of air, the pole face area of the active pole, and nominal air gap, respectively, and  $x$  and  $y$  are the journal displacements. The axial air gap reluctances are described as;

$$R_{zj} = \frac{g_{zj}}{\mu_0 a_{z0}} \quad (3)$$

$$\text{where } g_{z1} = g_{z0} - z, g_{z2} = g_{z0} + z \quad (4)$$

and where  $a_{z0}$  and  $g_{z0}$  are the axial pole face area and the nominal axial gap, respectively, and  $z$  is the rotor displacement along the axial direction. Applying Ampere's law and Gauss's law to the radial magnetic circuit leads to a matrix equation.

$$\begin{bmatrix} R_1 & -R_2 & 0 & 0 \\ 0 & R_2 & -R_3 & 0 \\ 0 & 0 & R_3 & -R_4 \\ 1 & 1 & 1 & 1 + \frac{R_4}{R_R} \end{bmatrix} \begin{bmatrix} \phi_1 \\ \phi_2 \\ \phi_3 \\ \phi_4 \end{bmatrix} = \begin{bmatrix} 0 \\ 0 \\ 0 \\ \frac{H_c L_{pm}}{\tilde{R}_R} \end{bmatrix} + \begin{bmatrix} 0 & 0 \\ 0 & 0 \\ 0 & 0 \\ -R_{z2} \tilde{n} & R_{z1} \tilde{n} \end{bmatrix} \begin{bmatrix} i_{z1} \\ i_{z2} \end{bmatrix} + \begin{bmatrix} n & -n & 0 & 0 \\ 0 & n & -n & 0 \\ 0 & 0 & n & -n \\ 0 & 0 & 0 & \frac{n}{R_R} \end{bmatrix} \begin{bmatrix} i_1 \\ i_2 \\ i_3 \\ i_4 \end{bmatrix} \quad (5)$$

where

$$R_R = \frac{R_p R_l}{R_p + R_l} + \frac{R_{z1} R_{z2}}{R_{z1} + R_{z2}} \quad \tilde{R}_R = R_p + \frac{R_{z1} R_{z2}}{R_{z1} + R_{z2}} \left(1 + \frac{R_p}{R_l}\right)$$

and  $\phi_j$ ,  $i_j$ ,  $i_{zj}$ ,  $n$ , and  $\tilde{n}$  are fluxes, currents through j-th pole, axial currents, the number of radial coil turns, and the number of axial coil turns, respectively. Equation (5) is rewritten in vector form as;

$$R\Phi = H + H_z I_z + NI \quad (6)$$

The flux densities in the gaps are reduced by flux leakage, fringing, and saturation of magnetic material. The flux density vector is then;

$$B = \zeta A^{-1} \Phi \quad (7)$$

where  $A = \text{diag}([a_0, a_0, a_0, a_0])$

The parameter  $\zeta$  represents flux fringing factor, and can be empirically estimated. Magnetic forces developed in the radial pole plane are described as;

$$F_\varphi = -B^T \frac{\partial D}{\partial \varphi} B \quad (8)$$

where the air gap energy matrix is;

$$D = \text{diag}(g_j a_0 / (2\mu_0)) \quad (9)$$

and where  $\varphi$  is either  $x$  or  $y$ . Applying Ampere's law and Gauss's law to the axial magnetic circuit leads to a matrix equation.

$$\begin{bmatrix} R_{z1} & -R_{z2} \\ 1 + \frac{R_{z1}}{R_A} & 1 \end{bmatrix} \begin{bmatrix} \phi_{z1} \\ \phi_{z2} \end{bmatrix} = \begin{bmatrix} 0 \\ \frac{-R_l H_c L_{pm}}{R_A (R_p + R_l)} - \frac{H_{eq}}{R_A} \end{bmatrix} + \begin{bmatrix} -\tilde{n} & -\tilde{n} \\ -\tilde{n} & 0 \end{bmatrix} \begin{bmatrix} i_{z1} \\ i_{z2} \end{bmatrix} \quad (10)$$

where

$$R_A = \frac{R_p R_l}{R_p + R_l} + R_{eq} \quad , \quad R_{eq} = \frac{1}{\frac{1}{R_1} + \frac{1}{R_2} + \frac{1}{R_3} + \frac{1}{R_4}} \quad ,$$

$$H_{eq} = \frac{\frac{ni_1}{R_1} + \frac{ni_2}{R_2} + \frac{ni_3}{R_3} + \frac{ni_4}{R_4}}{\frac{1}{R_1} + \frac{1}{R_2} + \frac{1}{R_3} + \frac{1}{R_4}}$$

Equation (10) can be rewritten in vector form as;

$$R_z \Phi_z = \tilde{H} + H_{xy} I + \tilde{N} I_z \quad (11)$$

$$H_{xy} = \begin{bmatrix} 0 & 0 & 0 & 0 \\ h_1 & h_2 & h_3 & h_4 \end{bmatrix}, \quad h_i = \frac{\frac{n}{R_i}}{R_A \left(\frac{1}{R_1} + \frac{1}{R_2} + \frac{1}{R_3} + \frac{1}{R_4}\right)}$$

The flux density vector is then;

$$B_z = \zeta_z A_z^{-1} \Phi_z \quad (12)$$

where  $A_z = \text{diag}([a_{z0}, a_{z0}])$

The parameter  $\zeta_z$  represents the flux fringing factor in the axial air gaps. Magnetic forces developed in the axial pole plane are described as;

$$F_z = -B_z^T \frac{\partial D_z}{\partial z} B_z \quad (13)$$

where the air gap energy matrix is;

$$D_z = \text{diag}([g_{z1} a_{z0} / (2\mu_0), g_{z2} a_{z0} / (2\mu_0)]) \quad (14)$$

### 3. FAULT TOLERANT CONTROL

The currents distributed to the radial poles are generally expressed as a distribution matrix  $T$  and control voltage vector  $v$ . The current vector is;

$$I = T v \quad (15)$$

where  $T = [T_x \ T_y]$ ,  $v = \begin{bmatrix} v_x \\ v_y \end{bmatrix}$ ,

$$T_x = [t_{x1} \ t_{x2} \ t_{x3} \ t_{x4}]^T, \quad T_y = [t_{y1} \ t_{y2} \ t_{y3} \ t_{y4}]^T,$$

and  $v_x$  and  $v_y$  are  $x$  and  $y$  control voltages, respectively. For example, the current distribution scheme for unfailed radial poles is;

$$\tilde{T} = \begin{bmatrix} 1 & 0 \\ 0 & 1 \\ -1 & 0 \\ 0 & -1 \end{bmatrix} \quad (16)$$

The currents distributed to the axial plane are expressed as;

$$I_z = T_z v_z \quad (17)$$

where  $T_z = \begin{bmatrix} t_{z1} \\ t_{z2} \end{bmatrix}$ , and  $v_z$  is  $z$  control voltage.

For example, the current distribution scheme for unfailed axial poles is;

$$\tilde{T}_z = \begin{bmatrix} 1 \\ 1 \end{bmatrix} \quad (18)$$

The remaining three currents, if one coil fails, are redistributed such that the same opposing poles, C-core like, control fluxes still can be realized. The calculated distribution matrix for the 4<sup>th</sup> coil failed operation is;

$$T_4 = \begin{bmatrix} 1 & 1 \\ 0 & 2 \\ -1 & 1 \\ 0 & 0 \end{bmatrix} \quad (19)$$

The nonlinear magnetic forces of  $F_x$ ,  $F_y$ , and  $F_z$  can be linearized about equilibrium positions and the control voltages by using Taylor series expansion. The linearized magnetic forces are;

$$\begin{bmatrix} F_x \\ F_y \\ F_z \end{bmatrix} = - \begin{bmatrix} k_{pxx} & k_{pxy} & k_{pxz} \\ k_{pyx} & k_{pyy} & k_{pyz} \\ k_{pzx} & k_{pzy} & k_{pzz} \end{bmatrix} \begin{bmatrix} x \\ y \\ z \end{bmatrix} + \begin{bmatrix} k_{vxx} & k_{vxy} & k_{vzx} \\ k_{vyx} & k_{vyy} & k_{vyz} \\ k_{vzx} & k_{vzy} & k_{vzz} \end{bmatrix} \begin{bmatrix} v_x \\ v_y \\ v_z \end{bmatrix} \quad (20)$$

$$\text{or} \quad F = -K_p Z + K_v V \quad (21)$$

The flux coupling between the axial and radial planes can be determined by the cross coupled stiffness properties of Eq. (20). The linearized magnetic forces calculated at the equilibrium points ( $x_0 = 2$  mils,  $y_0 = -1$  mils,  $z_0 = 3$  mils,  $v_{x0} = 0.5$  volts,  $v_{y0} = 0.3$  volts,  $v_{z0} = 1$  volts) after the 4-th radial coil and an axial coil failed operation are;

$$K_p = \begin{bmatrix} -939484.13 & -16547.43 & -10407.28 \\ 3011.03 & -968484.90 & 9227.66 \\ -13725.16 & 10856.53 & -2699194.87 \end{bmatrix}$$

$$K_v = \begin{bmatrix} 82.55 & 2.64 & 1.64 \\ 0.28 & 81.09 & -1.32 \\ 0.32 & 12.08 & 179.82 \end{bmatrix}$$

The fault-tolerant control scheme can be easily implemented in a physical controller (DSP). The controller consists of two independent parts, which are a feedback voltage control law and an adaptive current distribution mechanism. Though any control algorithm for magnetic bearing systems appearing in the literature can be utilized with the fault tolerant scheme, for sake of illustration, a simple PD feedback control law is used to stabilize the system.

$$v_{c\phi} = K_p \phi + K_d \dot{\phi} \quad (22)$$

$\phi \in (x, y)$

While the feedback control law remains unaltered during the failure the appropriate current distribution matrix  $T$  can be continuously updated using an adaptive current distribution mechanism. Failure status vectors and the corresponding distribution matrices for the 5 possible states including an unfailed vector can be tabulated in a reference table and stored in the DSP controller as a part of searching algorithm. The distribution matrix corresponding to the failure vector is implemented in the controller. By prior experience this series of actions for failure detection, searching for  $T$ , and replacement by the new  $T$  can be implemented in one loop time of a fast ( $> 15K \text{ sec}^{-1}$ ) DSP controller. Any one coil out of 4 coils is free to fail while bearing properties such as the load capacity and stiffness remain invariant, if  $\tilde{T}$  is replaced by  $T_1$ ,  $T_2$ ,  $T_3$ , and  $T_4$  shortly after failure.

#### 4. CONCLUSION

A fault tolerant current distribution scheme is developed for a bi-directional, permanent magnet biased, homopolar magnetic bearing. The bearing preserves the same magnetic forces before and after failure even though one coil among four radial coils and one coil of two axial coils fail. A one-dimensional circuit that represents the bi-directional bearing is analyzed to obtain the optimal bearing parameters such as the radial pole face area, number of coil turns, and permanent magnet size. The results show advantages of the fault tolerant scheme and bi-directional bearing improvements relative to conventional magnetic suspension. Fault tolerance of the magnetic bearing actuator can be achieved at the expense of additional hardware requirements and reduction of overall bearing load capacity.

These bidirectional magnetic bearings with fault tolerant capability can be used as robot joints. Since magnetic bearing supported robot arms can avoid oil lubrication and dust generation, they can be used for robots in clean environment, in vacuum chambers, or in space. They also have some more advantages over conventional robot joints such as frictionless manipulation, force control, force sensing, active

vibration control.

## REFERENCES

- [1] C.R. Meeks, E. DiRusso, G.V. Brown, "Development of a Compact, Light Weight Magnetic Bearing," AIAA Paper No. AIAA-90-2483 (1990)
- [2] E. H. Maslen and D. C. Meeker, "Fault Tolerance of Magnetic Bearings by Generalized Bias Current Linearization," *Magnetics – Transactions of the IEEE*, Vol. 31, pp. 2304 – 2314, 1995
- [3] E. H. Maslen, C. K. Sortore, G. T. Gillies, R. D. Williams, S. J. Fedigan, and R. J. Aimone, "A Fault Tolerant Magnetic Bearings," *Journal of Engineering for Gas Turbines and Power*, Vol. 121, pp. 504-508 , 1999
- [4] U. J. Na and A. B. Palazzolo, "Optimized Realization of Fault-Tolerant Heteropolar Magnetic Bearings for Active Vibration Control," *Journal of Vibration and Acoustics*, Vol. 121, pp. 504-508, 2000
- [5] U. J. Na and A. B. Palazzolo, "Fault Tolerance of Magnetic Bearings with Material Path Reluctances and Fringing Factors," *IEEE Transactions on Magnetics*, Vol. 36, pp. 3939 – 3946, 2001